



USER MANUAL

TABLE OF CONTENTS

The Basics	4
Getting Started	8
Camera Status Screen	16
Camera Menus	17
Camera Modes	20
Navigating Settings Menus	21
Video Mode	22
Photo Mode	25
Multi-Shot Mode	26
Setup Mode	31
Protune	34
Transferring Files to a Computer	38
Omni Files and GoPro Software	39
Smart Remote	40
Battery	41
Important Messages	44
Troubleshooting	46
Customer Support	48
Trademarks	48
Regulatory Information	48

THE BASICS

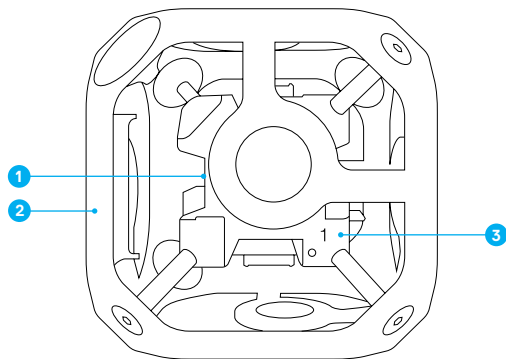

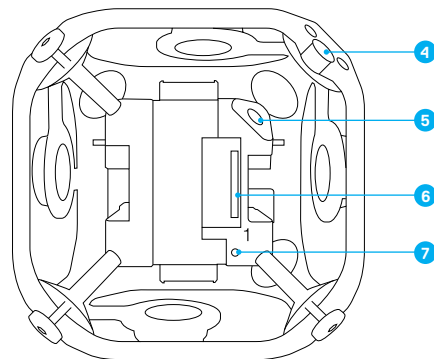

- 1. Inner Cube (Synchronizer)
- 2. Frame (6x Outer Panels)
- 3. Camera Position Indicator (1-6)
- 4. Mounting Corner
(1/4-20 Threaded Insert, 1x Top
under removable Corner Cap,
1x Bottom)
- 5. Power Connector
(2.5mm x 5.5mm)
- 6. HEROBus Connector (30-pin)
- 7. Array Camera Status Light

THE BASICS



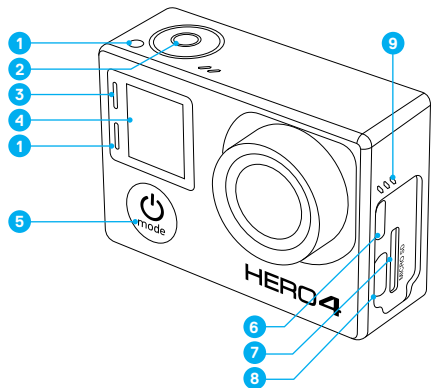

THE BASICS

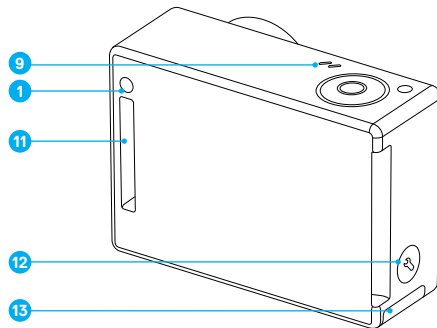

1. Camera Status Light (red)
2. Shutter/Select Button []
3. Wireless Status Light (blue)
4. Camera Status Screen
5. Power/Mode Button []
6. Micro HDMI Port (cable not included)
7. microSD Card Slot
8. Mini-USB Port (supports composite A/V cable/3.5mm stereo mic adapter, not included)
9. Audio Alert

THE BASICS



9. Microphone
11. HEROPort
12. Settings/Tag Button []
13. Battery Door

GETTING STARTED

MEMORY CARDS

HERO4 Black requires a microSD, microSDHC, or microSDXC memory card. The card must have a minimum rating of Class 10 or UHS-I, and a capacity of 32GB or 64GB. For a list of SD cards recommended for use with Omni, visit the Omni Support Hub at gopro.com/help.

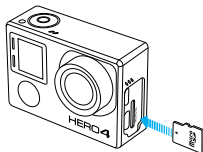

NOTICE: Use care when handling memory cards. Avoid liquids, dust and debris. As a precaution, power off the camera before inserting or removing the card. Check manufacturer guidelines regarding use in acceptable temperature ranges.



WARNING: Use caution when using your GoPro as part of your active lifestyle. Always be aware of your surroundings to avoid injury to yourself and others.

Abide by all local laws when using your GoPro and related mounts and accessories, including all privacy laws, which may restrict recording in certain areas.

GETTING STARTED

ROLE OF THE PRIMARY CAMERA

The camera that is connected to the inner cube and marked with 1 is referred to as the *primary camera*. All other cameras are referred to as *secondary cameras*.

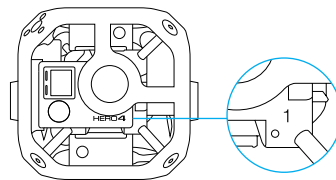

The primary camera controls all cameras in the array for these functions:

- Powers all cameras on/off
- Connects to the Smart Remote so that all cameras can be controlled remotely
- Displays *Array Ready* when the system is ready for use
- Displays *Array Error* when one of the secondary cameras experiences an error

GETTING STARTED

ASSEMBLING THE ARRAY

Installing the Cameras

The All Inclusive Omni package ships with the cameras already installed. If you want to re-install a camera or if you have the Rig Only version of Omni, follow the steps below.

1. Confirm that all cameras are HERO4 Black cameras. Other GoPros are not supported.
2. Confirm that all cameras are using the same version of array firmware. To obtain the latest array firmware for Omni, visit [gopro.com/help](https://community.gopro.com/help) and log in to the Omni Support Hub. If you need to create a support hub account, follow these instructions: <https://community.gopro.com/html/assets/GoProOmniSupportHub.pdf>.
3. Complete these steps for each camera:
 - a. Use the included hex key to loosen (but not remove) the screws on one of the panels.

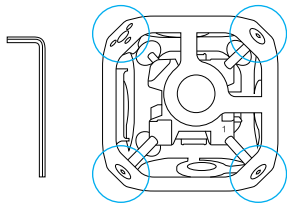

- b. Gently pull the panel off of the frame.

GETTING STARTED

- c. Connect a camera to the HEROBus connector on the inner cube.

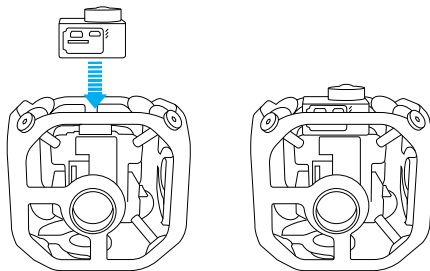

- d. Align the outer panel with the lens, then gently slide the panel onto the lens and move the corners into place.

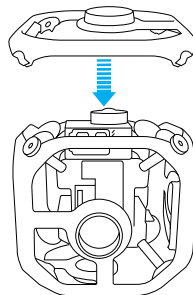

GETTING STARTED

- e. Tighten the screws in a star pattern.
4. Tighten the screws for the panel.
5. Repeat steps 3-6 for the remaining cameras.

SUPPLYING POWER TO THE RIG

You have two options for powering the rig: external power or the camera batteries.

NOTICE: Do not switch from one power source to another (camera batteries to external power or external power to camera batteries) without first powering off the cameras. Failure to follow this guideline can lead to unexpected powering off, interrupted recordings, and erratic Omni behavior.

Powering the Rig with External Power

For extended recording time, power the rig with an external power source.

1. Be sure that the battery for the external power unit is charged.
2. Remove the cameras from the rig.
3. Remove the batteries from the cameras.
4. Place the cameras in the rig.
5. Connect the power cable to the power connector.

NOTICE: Do not connect a high-voltage power source to Omni. Omni requires 5V input, but can be powered using a 12V to 5V step-down converter, such as the Core SWX / Switronix XP-DV-5GP. The Omni power connector is a 2.5mm x 5.5mm polarity plug. The step-down converter has an 8A rating.

Powering the Rig with Camera Batteries + Charging in the Rig

With these options, you can charge the camera batteries without removing the cameras from the rig.

- Using USB cables, connect the camera USB ports to the USB hub (available with the All Inclusive Omni package).

GETTING STARTED

- Use the power connector to connect the external power to the inner cube.

The camera status lights turn on during charging and turn off when charging is complete.

Powering the Rig with Camera Batteries + Charging Outside of the Rig

With this option, you must remove the cameras from the rig.

1. Insert the battery into the camera.

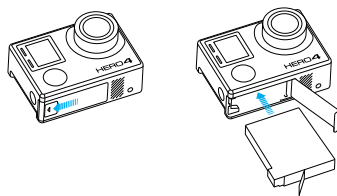

2. Connect the camera to a computer, USB hub, or other USB charging adapter using the included USB cable. The camera status light turns on during charging and turns off when charging is complete. When charging with a computer, be sure that the computer is connected to a power source. If the camera status light does not turn on, use a different USB port.

For more battery information, see [Battery](#) (page 10).

GETTING STARTED



WARNING: Use caution when using your GoPro as part of your active lifestyle. Always be aware of your surroundings to avoid injury to yourself and others.

Abide by all local laws when using your GoPro and related mounts and accessories, including all privacy laws, which may restrict recording in certain areas.

MOUNTING OMNI

1. If you want to use the top 1/4"-20 threaded insert, unscrew the corner cap.
2. Use a 1/4"-20 screw with the threaded insert on the top or bottom of the rig (near the power connector) to attach Omni to a monopod or other suitable mounting solution.

NOTICE: When removing Omni from a monopod or other mounting solution, disconnect the power connector first to avoid damaging the connection.

GETTING STARTED

POWERING ON + OFF ALL CAMERAS IN THE ARRAY

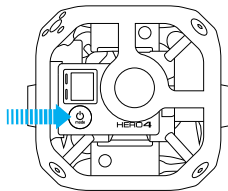

To Power On All Cameras:

Press the **Power/Mode** button [] on the primary camera. The camera status lights flash three times and the sound indicator emits three beeps. The primary camera powers up, followed by the secondary cameras. When *Array Ready* disappears, you can begin capturing video or photos.

The array is properly configured if the camera mode icon and *AR* alternate in the upper left of the camera status screen.

If *Array Error* appears on the primary camera's status screen, see [Array Error](#) (page 11).

To Power Off All Cameras:

Press and hold the **Power/Mode** button [] on the primary camera for three seconds. The camera status lights flash several times and the sound indicator emits seven beeps.









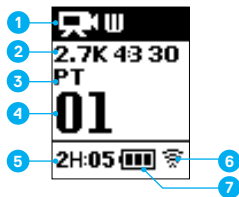





















CAMERA STATUS SCREEN

Your HERO4 Black features a status screen that displays the following information:

1. Camera Mode/FOV (field of view)
2. Resolution/fps (frames per second)
3. Protune™ (if on)
4. Number of Files Captured
5. Available Time on Memory Card
6. Wireless (if on)
7. Battery Life



CAMERA MENUS

	Beeps		Rate
	Burst		Reset Camera
	Color		Setup Mode
	Date/Time		Sharpness
	Delete		Shutter
	Exposure Value Compensation		Spot Meter
	Field of View		Time Lapse
	Frames Per Second		Time Lapse Video
	Interval		Video Format
	ISO Limit		Video Mode
	LEDs		Video Resolution
	Megapixels		White Balance
	Multi-Shot Mode		Wireless
	Night Lapse		
	Photo		
	Protune		

CAMERA MENUS

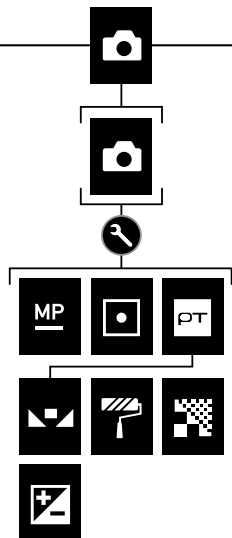
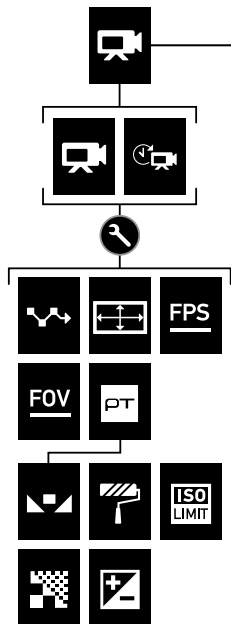



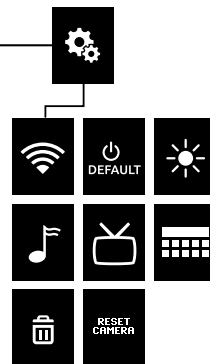
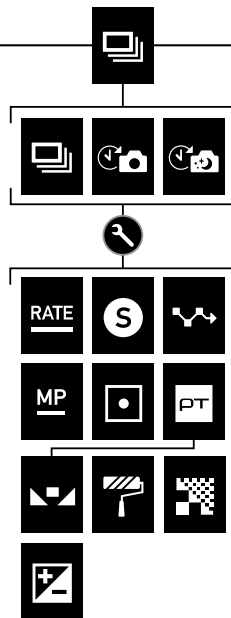

CAMERA MENUS



CAMERA MODES

The HERO4 Black features four camera modes. To cycle through the modes, press the **Power/Mode** button [].



	Video	Record video or time lapse video
	Photo	Capture single photos
	Multi-Shot	Capture a series of photos
	Setup	Adjust general camera settings

NAVIGATING SETTINGS MENUS

Each mode has its own settings menu. Follow the instructions below on your camera or the Smart Remote to navigate the settings menus.

For information about connecting the Smart Remote to your HERO4 Black cameras, see the Smart Remote User Guide at gopro.com/help.

TO NAVIGATE SETTINGS MENUS:

1. Verify that the camera is in the desired camera mode. To cycle between the modes, press the **Power/Mode** button [].
2. Press the **Settings/Tag** button [] to open the settings menu for that mode.
3. Use the **Power/Mode** button [] to cycle through the settings.

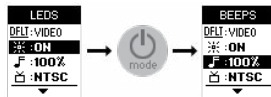

4. Press the **Shutter/Select** button [] to cycle through the options within a setting. To select an option, leave the option highlighted when you move to another screen.

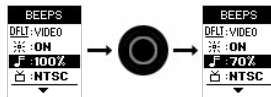







5. To go back to the previous screen or exit the settings menu, press the **Settings/Tag** button [].

VIDEO MODE

Video mode contains two capture modes: Video and Time Lapse Video.

Capture Mode	Description
Video (default)	Captures video.
Time Lapse Video	Creates video from frames captured at specific intervals. Time Lapse Video is captured without audio. Protune™ is not available in this capture mode.

CAPTURING VIDEO

1. Verify that the camera is in **Video** mode. If needed, press the **Power/Mode** button [] to change to **Video** mode.
2. If necessary, select a different video capture mode (Video or Time Lapse Video):
 - a. Press the **Settings/Tag** button [] to open the settings menu.
 - b. Press the **Shutter/Select** button [] repeatedly until you get to the desired capture mode.
 - c. Press the **Settings/Tag** button [] to close the settings menu. The icon for the selected capture mode appears in the upper left on your camera status screen.
3. Press the **Shutter/Select** button []. The camera beeps once and the camera status lights flash while the camera is recording.
4. To stop capturing, press the **Shutter/Select** button []. The camera status lights flash three times and the camera beeps three times.

If the memory card is full or the battery is out of power, your camera automatically stops recording. Your video is saved before the camera powers off.

VIDEO MODE

VIDEO SETTINGS

The capture mode that you select in **Video** mode determines the settings that appear in the rest of the menu.

For instructions on how to change the following settings, see [Navigating Settings Menus](#) (page 21).

PRO TIP: To open the settings menu for the current mode, press the **Settings/Tag** button [].

INTERVAL

The Interval setting applies to Time Lapse Video. Interval determines the amount of time that passes between each captured frame. Available intervals range from 2 seconds (default) to 60 seconds.

Interval	Examples
2 seconds	Busy street corner
5-10 seconds	Sunset
10-60 seconds	Lengthy activities, such as construction projects

Note: Time Lapse Video is not supported for 1440p50, 1440p60, and 960p120.

VIDEO MODE

CAPTURE RESOLUTION, FPS, AND FOV

With Omni, each HERO4 Black camera captures video at the following resolutions:

Video Resolution	FPS (NTSC/PAL)	FOV	Screen Resolution
2.7K 4:3	30/25	Wide	2704x2028, 4:3
1440p	60/50	Wide	1920x1440, 4:3
960p	120/120	Wide	1280x960, 4:3



High-Performance Video Modes, Camera Temperatures, and Battery Performance

When capturing video at 2.7K 4:3, it is normal for the cameras to become warm and use more power.

If a camera gets too hot, a message appears on the screen indicating that the cameras is shutting down. The camera stops recording, saves your video, and powers off. If this happens with a camera in Omni, let your camera sit and cool for 20 minutes before attempting to use it again.

For extended recording time, capture shorter video clips or remove the batteries from all cameras and use an external power source with the power connector on the rig.



PROTUNE

For details about Protune settings, see [Protune](#) (page 34).

PHOTO MODE

Photo mode contains one capture mode: Single photo.

CAPTURING PHOTOS



1. Verify that the camera is in **Photo** mode. If needed, press the **Power/Mode** button [] to change to **Photo** mode.
2. Press the **Shutter/Select** button []. The camera beeps two times, the camera status lights flash and the counter on the camera status screen increases by one.

PHOTO SETTINGS

For instructions on how to change the following settings, see [Navigating Settings Menus](#) (page 6).

PRO TIP: To open the settings menu for the current mode, press the **Settings/Tag** button [].



MEGAPIXELS

With Omni, each HERO4 Black captures photos at 12MP.



SPOT METER

Spot Meter lets you capture photos from a dark space while pointing the camera into a brighter setting, such as when recording the outdoors from within a car. When Spot Meter is turned on, [] appears on the camera status screen. The options for this setting are off (default) and on.



PROTUNE







For details about Protune settings, see [Protune](#) (page 9).

MULTI-SHOT MODE

Multi-Shot mode contains three capture modes: Burst, Time Lapse and Night Lapse.

Capture Mode	Description
Burst (default)	Captures up to 30 photos in 1 second. Perfect for capturing the definitive moment in fast-action sports.
Time Lapse	Captures a series of photos at specified intervals. You can use Time Lapse to capture photos of any activity, so you can choose the best ones later.
Night Lapse	Captures a series of photos at specific intervals and exposure times. Use Night Lapse in low light environments, such as when capturing the night sky over a period of time. For available exposure times and examples of when to use them, see Shutter (page 29).







CAPTURING BURST PHOTOS

1. Select Burst mode:
 - a. Press the **Power/Mode** button [] repeatedly until you get to **Multi-Shot** mode.
 - b. Press the **Settings/Tag** button [] to open the settings menu.
 - c. Press the **Shutter/Select** button [] repeatedly until you get to Burst.
 - d. Press the **Settings/Tag** button [] to close the settings menu. The Burst icon [] appears in the upper left on your camera status screen.
2. Press the **Shutter/Select** button []. The camera status lights flash and the camera beeps multiple times.

See [Rate](#) (page 28) for options available for Burst photos.

MULTI-SHOT MODE

CAPTURING TIME LAPSE OR NIGHT LAPSE PHOTOS

1. Select the desired multi-shot capture mode (Time Lapse or Night Lapse):
 - a. Press the **Power/Mode** button [] repeatedly until you get to **Multi-Shot** mode.
 - b. Press the **Settings/Tag** button [] to open the settings menu.
 - c. Press the **Shutter/Select** button [] repeatedly until you get to the desired capture mode (Time Lapse or Night Lapse).
 - d. Press the **Settings/Tag** button [] to close the settings menu. The icon for the selected capture mode appears in the upper left on your camera status screen.
2. Press the **Shutter/Select** button []. The camera initiates countdown and the camera status lights flash each time a photo is captured.
3. To stop capturing, press the **Shutter/Select** button []. The camera status lights flash three times and the camera beeps three times.

MULTI-SHOT SETTINGS

The capture mode that you select determines the **Multi-Shot** settings that appear in the rest of the menu.

For instruction on how to change the following settings, see [Navigating Settings Menus](#) (page 6).

MULTI-SHOT MODE

RATE RATE

Rate applies only to Burst. Photos can be captured at the following rates:

3 photos in 1 second

5 photos in 1 second

10 photos in 1 second

10 photos in 2 seconds

10 photos in 3 seconds

30 photos in 1 second (default)

30 photos in 2 seconds

30 photos in 3 seconds

30 photos in 6 seconds

MULTI-SHOT MODE

S SHUTTER

Shutter applies only to Night Photo and Night Lapse and determines the amount of time that the shutter is open. The options for this setting are auto (up to 2 seconds), 2, 5, 10, 15, 20 or 30 seconds. The default setting is auto.

Settings	Examples
Auto (up to 2 sec)	Sunrise, sunset, dawn, dusk, twilight, night
2 sec, 5 sec, 10 sec	Dawn, dusk, twilight, traffic at night, Ferris wheel, fireworks, light painting
20 sec	Night sky (with light)
30 sec	Night stars, Milky Way (complete darkness)

MULTI-SHOT MODE

INTERVAL

Interval applies only to Time Lapse and Night Lapse. Interval determines the amount of time that passes between each captured frame.

Time Lapse Intervals

Available intervals for Time Lapse range from 0.5 seconds (default) to 60 seconds.

Interval	Examples
0.5-2 seconds	Surfing, biking or other sport
2 seconds	Busy street corner
5-10 seconds	Sunset
10-60 seconds	Lengthy activities, such as construction projects

Night Lapse Intervals

Available intervals for Night Lapse range from 4 seconds to 60 minutes. Continuous (default) causes the Interval to match the Shutter setting. For example, if Shutter is set to 10 seconds and Interval is set to continuous, your camera captures a photo every 10 seconds.

MP MEGAPIXELS

With Omni, each HERO4 Black captures photos at 12MP.

SETUP MODE

Setup mode contains settings for wireless and settings to customize your camera. For instructions on how to change the following settings, see [Navigating Settings Menus](#) (page 6).

WIRELESS

For Omni, this setting applies *only* to the primary camera. Wireless must be off for all secondary cameras.

When the primary camera's Wireless is on, a Wireless status icon appears on the camera status screen and the blue wireless lights on the camera blink intermittently. The default setting for Wireless is off.

Setting	Description
PAIR	Lets you pair your primary camera to a GoPro remote. For more information, see Smart Remote (page 10).
MODE	After pairing, Mode lets you connect the primary camera to a GoPro remote.

PRO TIP: If you forgot your camera's name or password, use the Camera Reset setting (Reset Wi-Fi option) in the primary camera's **Setup** mode to reset them to the defaults. The default password is *goprohero*.

DEFAULT MODE

You can select the capture mode that appears when the camera powers on. The options are Video, Time Lapse Video and Single Photo.

SETUP MODE



LEDS

This setting determines which camera status lights (red) to activate. The options for this setting are 4 (top, bottom, front, back), 2 (front and back), or off (none). The default setting is 4.

Note: The Wireless status light (blue) is always activated unless you select off for this setting.



BEEPS

You can set the volume for the sound indicators to be 100% (default), 70% or off.



VIDEO FORMAT

The Video Format setting governs frame rates for recording and playback when viewing video on a TV/HDTV.

Setting	Description
NTSC (default)	Viewing video in North America
PAL	Viewing video on a PAL TV/HDTV (most televisions outside of North America)



DATE/TIME

This setting lets you set the date and time. If the battery is removed from the camera for an extended period of time, you must reset the date and time.

SETUP MODE



DELETE

This setting lets you delete the last file, or delete all files and format the memory card. Deleting all files is useful after you transfer your files to your computer and want to make room on your memory card for more content. LED lights blink until the operation is complete.

NOTICE: If you select All/Format, the memory card is reformatted, which deletes every file on the card. If you select this option from the primary camera, memory cards in *all* cameras are reformatted.

CAMERA RESET

With this setting, you can reset your camera's settings to their default values. This option retains the Date/Time setting, and remote control pairing.

PROTUNE

PROTUNE BENEFITS

Protune unlocks the camera's full potential, yielding stunning image quality and cinema-caliber video optimized for professional productions.

Protune is compatible with professional color correction tools, GoPro software and other video editing software.



PROTUNE

The options for this setting are off (default) and on. When Protune is on, *PT* appears on the camera status screen. Protune is available for all video and photo resolutions.



WHITE BALANCE

White balance adjusts the overall color tone of videos based on the environmental conditions.

Note: Array camera firmware does not offer the Auto white balance selection. Be sure to choose the appropriate white balance for your scene.

Setting	Description
3000K	Warm light (incandescent or sunrise/sunset lighting)
5500K (default for Night Lapse)	Slightly cool light (cool fluorescent or average daylight)
6500K	Cool light (overcast conditions)
Native (default)	Minimally color-corrected file from the image sensor that allows for more precise adjustments in post-production

PROTUNE



COLOR

Color lets you adjust the color profile of your video and photos.

Setting	Description
GoPro Color	Provides GoPro color-corrected profile (same great color as when Protune is off)
Flat (default)	Provides a neutral color profile that can be color-corrected to better match footage captured with other equipment, offering more flexibility in post-production. Due to its long curve, Flat captures more details in shadows and highlights.

PROTUNE



ISO LIMIT

ISO Limit adjusts the camera's sensitivity in low-light environments, and creates a balance between brightness and resulting image noise. Image noise refers to the degree of graininess in the image.

Setting	Resulting Quality
6400	Brighter video in low light, highest image noise
3200	Brighter video in low light, increased image noise
1600 (default)	Moderately bright video in low light, moderate image noise
800	Darker video in low light, marginal image noise
400	Darker video in low light, minimum image noise



SHARPNESS

Sharpness controls the sharpness of your video footage.

Sharpness Setting	Resulting Quality
High (default)	Ultra-sharp video
Medium	Moderately sharp video
Low	Softer video

PROTUNE



EXPOSURE VALUE COMPENSATION (EV COMP)

Exposure Value Compensation affects the brightness of your video. Adjusting this setting can improve image quality when shooting in environments with contrasting lighting conditions.

Settings

-2.0	-1.5	-1.0	-0.5	0 (default)	+0.5	+1.0	+1.5	+2.0
------	------	------	------	-------------	------	------	------	------

PRO TIP: Exposure Value Compensation adjusts brightness within the existing ISO Limit. If brightness has already reached the ISO Limit in a low-light environment, increasing the Exposure Value Compensation does not have any effect.

RESET

This option resets all Protune settings to their default values.

TRANSFERRING FILES TO A COMPUTER

Remove the microSD cards from the cameras. Complete these steps for each microSD card:

1. Connect the card reader to your computer.
2. Insert the microSD card into the reader.
3. Transfer your files to your computer.
4. If appropriate, delete the files from your cards.

NOTICE: Be sure to back up your files before deleting them.

OMNI FILES AND GOPRO SOFTWARE

Files recorded with Omni are optimized for use with GoPro Omni Importer. This application offers unique functionality for Omni files: fast previewing, color correction, image stabilization, file export, and media management tools.

You can also use Omni files with GoPro Autopano Video Pro software for advanced stitching, stabilizing, and VR content publishing. Content created using the GoPro Omni Importer and GoPro Autopano Video Pro can be used with GoPro VR (available for iOS® and Android) and GoPro VR for desktop. For more information, visit kolor.com and refer to the user manuals for these apps.

Note: Omni recordings were not designed to work with the GoPro App (mobile or desktop) or Quik™.

SMART REMOTE

The Smart Remote can control your cameras from up to 600' (180m) away in optimal conditions with a clear line of sight between the Smart Remote and the Omni. To use the Smart Remote with Omni, pair it only with the primary camera. You can then control all 6 cameras remotely.

For information about connecting the Smart Remote to your HERO4 Black cameras, see the Smart Remote User Guide at gopro.com/help.

Note: You cannot use more than one Smart Remote with Omni or control more than one Omni with a Smart Remote.

BATTERY

MAXIMIZING BATTERY LIFE

The battery icon on the camera screen blinks when the battery drops below 10%. If the battery in any of the cameras reaches 0% while recording, the camera saves the file and the array powers off.

Extreme cold temperatures can decrease battery life. To maximize battery life in cold conditions, keep the camera in a warm place prior to use.

CHARGING INFORMATION

The battery charges to 100% in approximately two hours when using GoPro's USB-compatible Wall or Auto Charger (both sold separately).

When charging with a computer, be sure that the computer is connected to a power source. If the camera status light does not turn on, use a different USB port.

The included lithium-ion battery comes partially charged. No damage occurs to the camera or battery if used prior to a full charge.

You can also charge the battery outside the camera using the HERO4 Dual Battery Charger (sold separately).

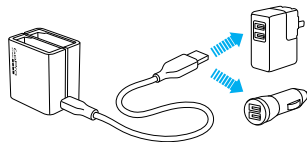

WARNING: Using a wall charger other than a GoPro Wall Charger can damage the GoPro battery and could result in fire or leakage. Only use chargers marked: Output 5V 1A. If you do not know the voltage and current of your charger, use the included USB cable to charge the camera from your computer.

BATTERY

REMOVING THE BATTERY FROM THE CAMERA

The HERO4 Black battery is designed to have a tight fit to maximize reliability in high-vibration activities.

To Remove the Battery:

1. Open the battery door by placing your thumb in the indentation in the battery door (on the bottom of the camera) and sliding it to the left. Allow the door to open.
2. Grasp the battery pull-tab and remove the battery from the camera.



WARNING: Only use manufacturer-recommended replacement batteries for your camera.

BATTERY STORAGE AND HANDLING

The camera contains sensitive components, including the battery. Avoid exposing your camera and battery to very cold or very hot temperatures. Low or high temperature conditions may temporarily shorten the battery life or cause the camera to temporarily stop working properly. Avoid dramatic changes in temperature or humidity when using the camera, as condensation may form on or within the camera.

Do not turn on your camera if it is wet. If your camera is already on, turn it off and remove the battery immediately. Allow the camera to dry thoroughly before using it again. Do not dry the camera or battery with an external heat source such as a microwave oven or hair dryer. Damage to the camera or battery caused by contact with liquid is not covered under the warranty.

BATTERY



WARNING: Do not drop, disassemble, open, crush, bend, deform, puncture, shred, microwave, incinerate or paint the camera or the battery, if it is removable. Do not insert foreign objects into any opening on the camera. Do not use the camera or the battery if it has been damaged—for example, if cracked, punctured or harmed by water. Disassembling or puncturing the battery (whether integrated or removable) can cause an explosion or fire.

Do not store your battery with metal objects, such as coins, keys or necklaces. If the battery terminals come in contact with metal objects, this may cause a fire.

BATTERY DISPOSAL

Most rechargeable lithium-ion batteries (whether removable or integrated into the camera) are classified as non-hazardous waste and are safe for disposal in the normal municipal waste stream. Many localities have laws in place requiring battery recycling. Check your local laws to make sure that you can dispose of rechargeable batteries in your regular trash. To safely dispose of lithium-ion batteries, protect terminals from exposure to other metal with packing, masking or electrical tape so they do not cause a fire while being transported.

Lithium-ion batteries, however, do contain recyclable materials and are accepted for recycling by the Rechargeable Battery Recycling Corporation's (RBRC) Battery Recycling Program. We encourage you to visit Call2Recycle at call2recycle.org or call 1-800-BATTERY in North America to find a convenient recycling location.

Never dispose of a battery in a fire because it may explode.

IMPORTANT MESSAGES

MICROSD CARD MESSAGES

If you cannot capture video, one of the microSD cards may be missing, full, or experiencing an error.

NO SD	No card present. The camera requires a microSD, microSDHC or microSDXC card (sold separately) to capture videos.
FULL	Card is full. Delete files or swap card.
SD ERR	Camera is unable to read card formatting. Reformat the card in the camera.

PRO TIP: Reformat your microSD cards before each shooting session to ensure that the cards remain in good condition.

ARRAY ERROR

If *Array Error* appears on the primary camera, check the secondary cameras for errors and improper connections. To identify the secondary camera that is experiencing the error, refer to its light on the inner cube.

- No light on the inner cube:
 - The camera has no battery installed or the battery needs charging
 - The camera is not running array camera firmware or is running a different firmware version than the other cameras in the array
- Red light on in the inner cube is blinking:
 - The camera has no microSD card
 - The camera's microSD card has an error

Be sure to resolve any issues before attempting to record.

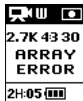

IMPORTANT MESSAGES

FILE REPAIR ICON



If your last video file was corrupted during recording, the camera displays the File Repair icon while it tries to repair the file. When this process is finished, press any button to continue using the camera.

TEMPERATURE ICON



The Temperature icon appears on the camera status screen when the camera becomes too hot and needs to cool down. If this happens with a camera in Omni, let it sit and cool for 20 minutes before attempting to use it again. Your camera was designed to identify conditions of overheating and is designed to respond accordingly.

TROUBLESHOOTING

MY GOPRO WON'T POWER ON

Make sure the camera's battery is charged or the array is connected to an external power supply.

OMNI UNEXPECTEDLY POWERS OFF

Omni might unexpectedly power off for a number of reasons:

- Insufficient power to the array from an external power supply
- Insufficient power to the array from the camera batteries
- Insufficient, incorrect, or excessive voltage/ampereage from an external power supply
- Missing camera from the array
- Camera without array camera firmware
- Fully depleted or nearly depleted camera battery
- Full microSD cards (no action was taken when *SD CARD FULL* message appeared on a camera)

CAMERAS IN OMNI WON'T RECORD

Check the cameras for errors:

- If the primary camera has a problem, the camera status screen displays a message describing the problem. For more information, see [Important Messages](#) (page 11).
- If one of the secondary cameras has a problem, the primary camera displays *Array Error* and the camera status light on the primary camera flashes rapidly. For more information, see [Array Error](#) (page 11).

MY OMNI ISN'T BEHAVING AS EXPECTED

This issue is often caused by switching from one power source to another when the camera is powered on. To switch from camera batteries to external power (or external power to batteries), you must first power off the camera.

TROUBLESHOOTING

Omni takes a moment to recognize the external voltage being supplied.

- Without camera batteries installed, Omni might not respond to a rapid attempt to power up, if the external power supply was not yet recognized.
- With camera batteries, a rapid power up might lead to the camera batteries initially powering up the Omni and then switching over to the external power.

To prevent these situations, wait a moment after connecting the external power before powering up Omni.

Note: When camera batteries are installed, check the camera status lights to determine if the external power is recognized. Unless the camera batteries are fully charged, the status lights illuminate after the external power is recognized.

MY GOPRO WON'T RESPOND WHEN I PRESS A BUTTON

Press and hold the **Power/Mode** button [] for 8 seconds to reset your camera. This reset saves all of your content and settings, and powers off your camera.

I WANT TO RESET MY GOPRO SETTINGS TO THE DEFAULTS

In **Setup** mode, select Camera Reset, and then select Reset Defaults. This option does not reset the Date/Time.

I POWERED OFF MY GOPRO, BUT THE BLUE LIGHT IS STILL BLINKING

The blue light indicates that Wireless is on. To turn off Wireless, go to **Setup** mode. Press the **Shutter/Select** button [] to select Wireless, then press it again to turn Wireless off.

For more answers to commonly asked questions, see gopro.com/help.

CUSTOMER SUPPORT

GoPro is dedicated to providing the best possible service. To reach GoPro Customer Support, visit gopro.com/help.

TRADEMARKS

GoPro, HERO, Protune, SuperView, and their respective logos are trademarks or registered trademarks of GoPro, Inc. in the United States and other countries. All other trademarks are the property of their respective owners. © 2016 GoPro, Inc. All rights reserved.

REGULATORY INFORMATION

To see the complete list of country certifications, refer to the Important Product + Safety Instructions included with Omni or visit gopro.com/help.

